

CAN FD Transceiver with Silent Mode

Features

- Silent Mode is Useful in the Following Applications:
 - Disables transmitter in redundant systems
 - Implements babbling idiot protection
 - Tests connection of bus medium
 - Prevents a faulty CAN controller from disrupting all network communications
- Optimized for CAN FD at 2, 5 and 8 Mbps Operation:
 - Maximum propagation delay: 120 ns
 - Loop delay symmetry: $\pm 10\%$ (2 Mbps)
- Meets or Exceeds Stringent Automotive Design Requirements Including “Hardware Requirements for LIN, CAN and FlexRay Interfaces in Automotive Applications”, Version 1.3, May 2012:
 - Conducted emissions at 2 Mbps with Common-Mode Choke (CMC)
 - DPI at 2 Mbps with CMC
- Meets SAE J2962/2 “Communication Transceivers Qualification Requirements – CAN”
 - Passes radiated emissions at 2 Mbps without a CMC
- Meets Latest ISO/DIS-11898-2:2015
- Meets Latest SAE J2284-4 and -5 Working Drafts
- Digital Inputs of the MCP2557FD are Compatible to 3.3V and 5V Microcontrollers. RXD Output Requires a 5V Tolerant Microcontroller Input
- Functional Behavior Predictable Under all Supply Conditions:
 - Device is in Unpowered mode if VDD drops below Power-on Reset (POR) level
 - Device is in Unpowered mode if VIO drops below POR level

Applications

CAN 2.0 and CAN FD networks in Automotive, Industrial, Aerospace, Medical, and Consumer applications.

MCP2557FD/8FD Family Members

Device	Vio Pin	NC	TTL I/O	Vio I/O	Description
MCP2557FD	N/A	Yes	Yes	N/A	—
MCP2558FD	Yes	N/A	N/A	Yes	Internal level shifter on digital I/O pins.

Note: For ordering information, see the [Product Identification System](#) section.

Description

The MCP2557FD/8FD CAN transceiver family is designed for high-speed CAN FD applications with up to 8 Mbps communication speed. The maximum propagation delay was improved to support longer bus length.

The device meets automotive requirements for CAN FD bit rates exceeding 2 Mbps, low quiescent current, electromagnetic compatibility (EMC) and electrostatic discharge (ESD).

Package Types

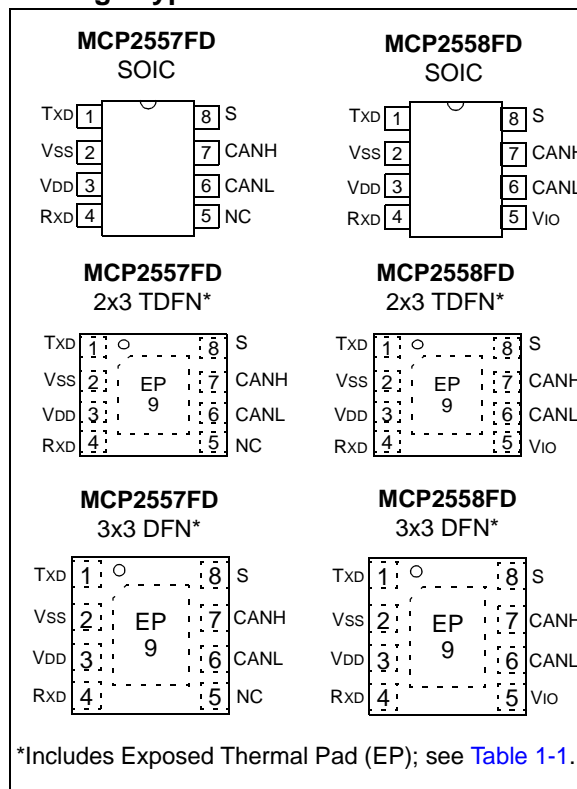

MCP2557FD/8FD

Block Diagram

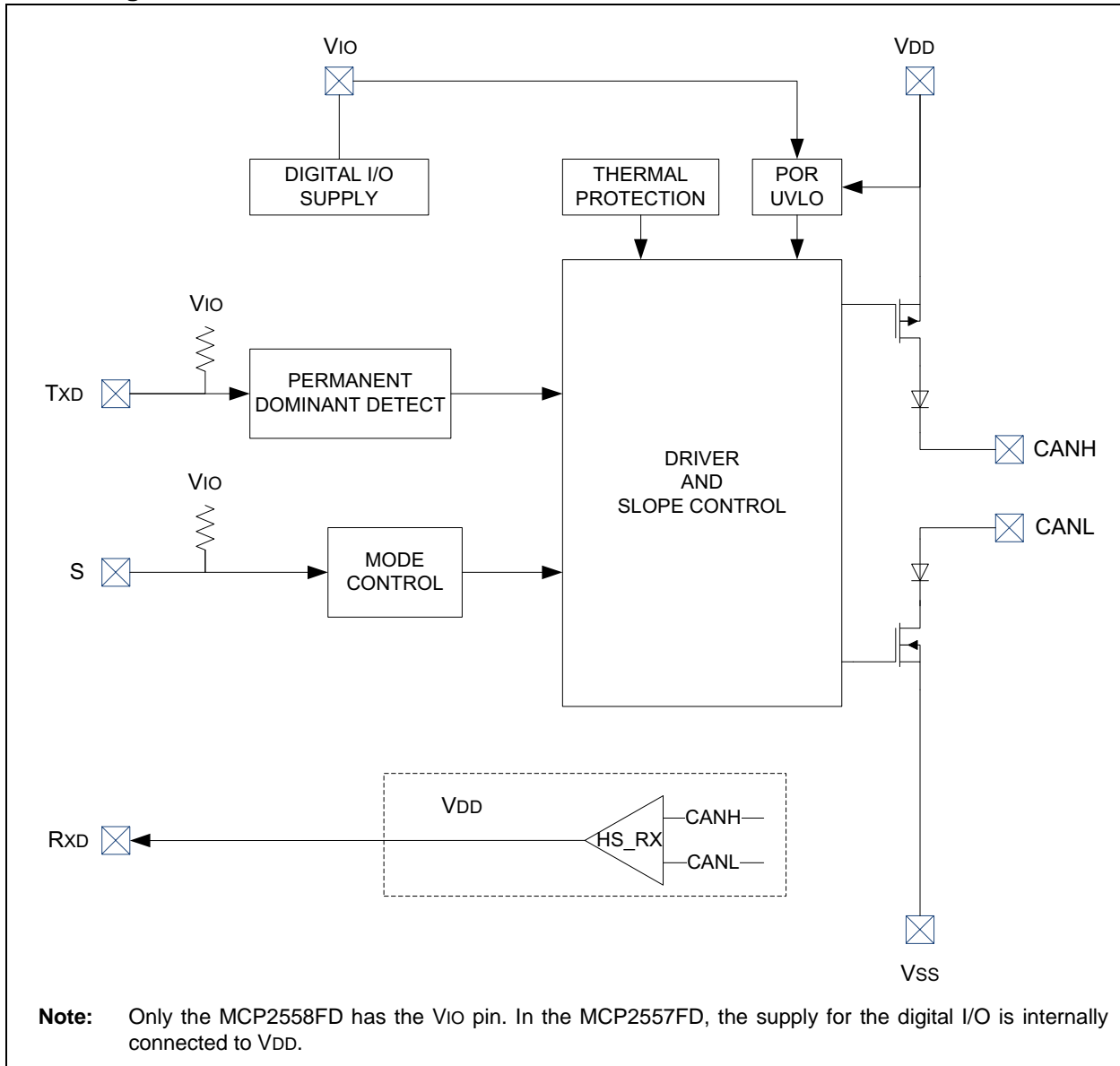

1.0 DEVICE OVERVIEW

The MCP2557FD/8FD CAN transceiver family is designed for high-speed CAN FD applications with up to 8 Mbps communication speed. The product offers a Silent mode controlled by the Silent mode pin. The Silent mode is used to disable the CAN transmitter. This ensures that the device doesn't drive the CAN bus. The MCP2557FD/8FD device provides differential transmit and receive capability for the CAN protocol controller, and is fully compatible with specification ISO/DIS-11898-2:2015.

The loop delay symmetry is tested to support data rates that are up to 8 Mbps for CAN FD (Flexible Data rate). The maximum propagation delay was improved to support longer bus length.

Typically, each node in a CAN system must have a device convert the digital signals generated by a CAN controller to signals suitable for transmission over the bus cabling (differential output). It also provides a buffer between the CAN controller and the high-voltage spikes that can be generated on the CAN bus by outside sources.

1.1 Transmitter Function

The CAN bus has two states: Dominant and Recessive. A Dominant state occurs when the differential voltage between CANH and CANL is greater than $V_{DIFF(D)}(I)$. A Recessive state occurs when the differential voltage is less than $V_{DIFF(R)}(I)$. The Dominant and Recessive states correspond to the Low and High states of the TXD input pin, respectively. However, a Dominant state initiated by another CAN node will override a Recessive state on the CAN bus.

1.2 Receiver Function

The RXD output pin reflects the differential bus voltage between CANH and CANL. The Low and High states of the RXD output pin correspond to the Dominant and Recessive states of the CAN bus, respectively.

1.3 Internal Protection

CANH and CANL are protected against battery short circuits and electrical transients that can occur on the CAN bus. This feature prevents destruction of the transmitter output stage during such a fault condition.

The device is further protected from excessive current loading by thermal shutdown circuitry that disables the output drivers when the junction temperature exceeds a nominal limit of +175°C.

All other parts of the chip remain operational, and the chip temperature is lowered due to the decreased power dissipation in the transmitter outputs. This protection is essential to guard against bus line short-circuit-induced damage. Thermal protection is only active during Normal mode.

1.4 Permanent Dominant Detection

The MCP2557FD/8FD device prevents a permanent dominant condition on TXD.

In Normal mode, if the MCP2557FD/8FD detects an extended Low state on the TXD input, it will disable the CANH and CANL output drivers in order to prevent data corruption on the CAN bus. The drivers will remain disabled until TXD goes High. The high-speed receiver is active, and data on the CAN bus is received on RXD.

The condition has a time-out of 1.9 ms (typical). This implies a maximum bit time of 128 μ s (7.8 kHz), allowing up to 18 consecutive dominant bits on the bus.

1.5 Power-on Reset (POR) and Undervoltage Detection

The MCP2557FD/8FD have POR detection on both supply pins, VDD and VIO. Typical POR thresholds to deassert the reset are 1.2V and 3.0V for VIO and VDD, respectively.

When the device is powered on, CANH and CANL remain in a high-impedance state until VDD exceeds its undervoltage level. Once powered on, CANH and CANL will enter a high-impedance state if the voltage level at VDD drops below the undervoltage level, providing voltage brown-out protection during normal operation.

The receiver output is forced to a Recessive state during an undervoltage condition on VDD.

MCP2557FD/8FD

1.6 Mode Control

Figure 1-1 shows the state diagram of the MCP2557FD/8FD.

1.6.1 UNPOWERED MODE (POR)

The MCP2557FD/8FD enters Unpowered mode if any of the following conditions occur:

- After powering up the device
- If VDD drops below VPORL
- If VIO drops below VPORL_VIO

In Unpowered mode, the CAN bus will be biased to ground using a high impedance. The MCP2557FD/8FD is not able to communicate on the bus.

1.6.2 WAKE MODE

The MCP2557FD/8FD transitions from Unpowered mode to Wake mode when VDD and VIO are above their PORH levels. From Normal mode, if VDD is smaller than VUVL, or if the bandgap output voltage is not within valid range, the device will also enter Wake mode.

In Wake mode, the CAN bus is biased to ground and RXD is always high.

1.6.3 NORMAL MODE

When VDD exceeds VUVH, the band gap is within valid range and TXD is High, the device transitions into Normal mode. During POR, when the microcontroller powers up, the TXD pin could be unintentionally pulled down by the microcontroller powering up. To avoid driving the bus during a POR of the microcontroller, the transceiver proceeds to Normal mode only after TXD is high.

In Normal mode, the driver block is operational and can drive the bus pins. The slopes of the output signals on CANH and CANL are optimized to reduce Electromagnetic Emissions (EME). The CAN bus is biased to VDD/2.

The high-speed differential receiver is active.

1.6.4 SILENT MODE

The device may be placed in Silent mode by applying a high level to the 'S' pin (pin 8). In Silent mode, the transmitter is disabled and the CAN bus is biased to VDD/2. The high-speed differential receiver is active.

The CAN controller must put the MCP2557FD/8FD back into Normal mode to enable the transmitter.

FIGURE 1-1: MCP2557FD/8FD STATE DIAGRAM

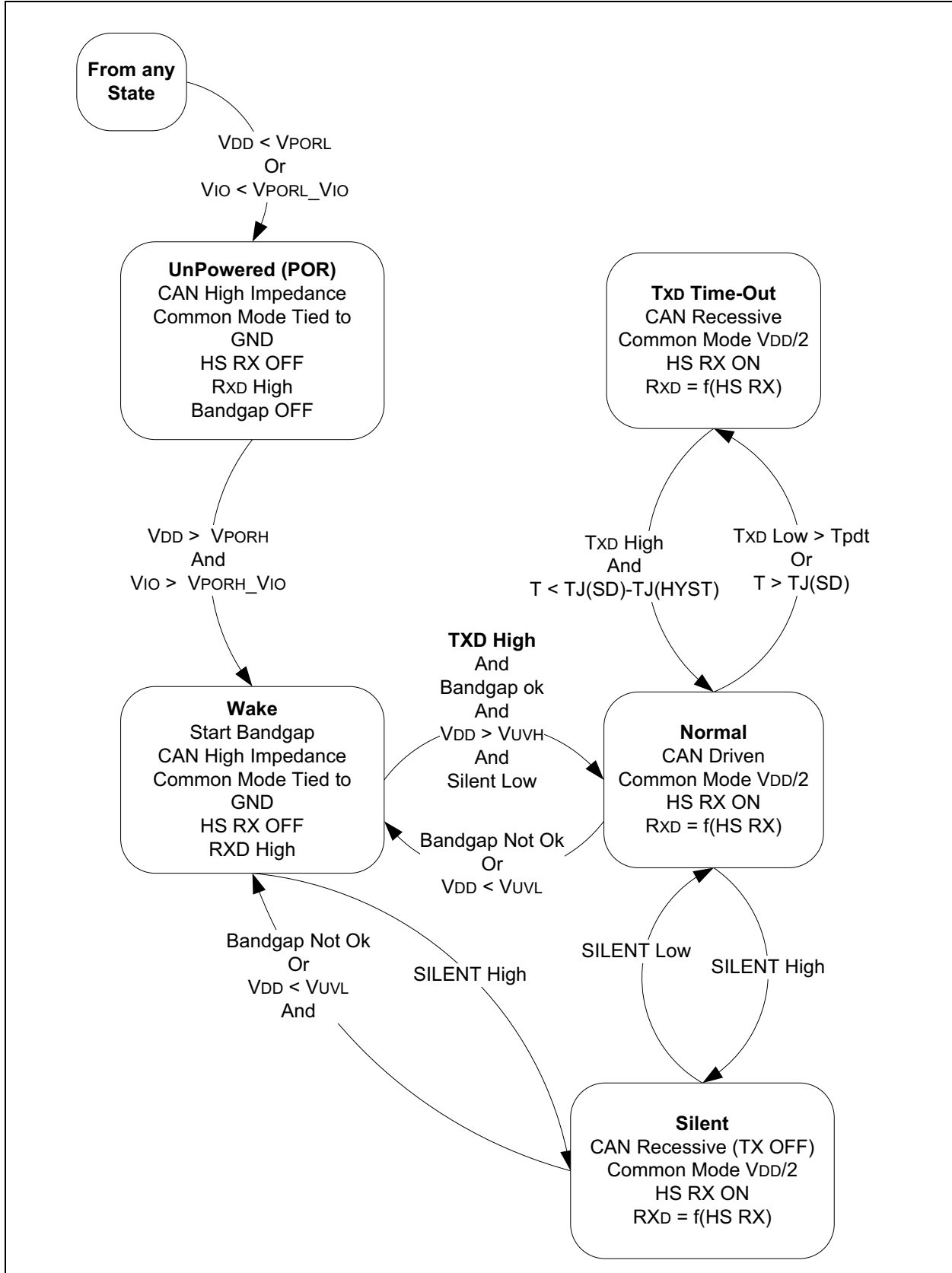

MCP2557FD/8FD

1.7 Pin Descriptions

The descriptions of the pins are listed in [Table 1-1](#).

TABLE 1-1: MCP2557FD/8FD PIN DESCRIPTIONS

MCP2557FD 3 x 3 DFN, 2 x 3 TDFN	MCP2557FD SOIC	MCP2558FD 3 x 3 DFN, 2 x 3 TDFN	MCP2558FD SOIC	Symbol	Pin Function
1	1	1	1	TXD	Transmit Data Input
2	2	2	2	VSS	Ground
3	3	3	3	VDD	Supply Voltage
4	4	4	4	RXD	Receive Data Output
5	5	—	—	NC	No Connect (MCP2557FD only)
—	—	5	5	VIO	Digital I/O Supply Pin (MCP2558FD only)
6	6	6	6	CANL	CAN Low-Level Voltage I/O
7	7	7	7	CANH	CAN High-Level Voltage I/O
8	8	8	8	S	Silent Mode Input
9	—	9	—	EP	Exposed Thermal Pad

1.7.1 TRANSMITTER DATA INPUT PIN (TXD)

The CAN transceiver drives the differential output pins CANH and CANL according to TXD. It is usually connected to the transmitter data output of the CAN controller device. When TXD is Low, CANH and CANL are in the Dominant state. When TXD is High, CANH and CANL are in the Recessive state, provided that another CAN node is not driving the CAN bus with a Dominant state. TXD is connected from an internal pull-up resistor (nominal 33 k Ω) to VDD or VIO, in the MCP2557FD or MCP2558FD, respectively.

1.7.2 GROUND SUPPLY PIN (VSS)

Ground supply pin.

1.7.3 SUPPLY VOLTAGE PIN (VDD)

Positive supply voltage pin. Supplies transmitter and receiver.

1.7.4 RECEIVER DATA OUTPUT PIN (RXD)

RXD is a CMOS-compatible output that drives High or Low depending on the differential signals on the CANH and CANL pins, and is usually connected to the receiver data input of the CAN controller device. RXD is High when the CAN bus is Recessive, and Low in the Dominant state. RXD is supplied by VDD or VIO, in the MCP2557FD or MCP2558FD, respectively.

1.7.5 NC PIN (MCP2557FD)

No Connect. This pin can be left open or connected to VSS.

1.7.6 VIO PIN (MCP2557FD)

Supply for digital I/O pins. In the MCP2557FD, the supply for the digital I/O (TXD, RXD and S) is internally connected to VDD.

1.7.7 DIGITAL I/O

The MCP2557FD/8FD enable easy interfacing to MCUs with I/O ranges from 1.8V to 5V.

1.7.7.1 MCP2557FD

The VIH(MIN) and VIL(MAX) for TXD are independent of VDD. They are set at levels that are compatible with 3V and 5V microcontrollers.

The RXD pin is always driven to VDD; therefore, a 3V microcontroller will need a 5V tolerant input.

1.7.7.2 MCP2558FD

VIH and VIL for S and TXD depend on VIO. The RXD pin is driven to VIO.

1.7.8 CAN LOW PIN (CANL)

The CANL output drives the Low side of the CAN differential bus. This pin is also tied internally to the receive input comparator. CANL disconnects from the bus when the MCP2557FD/8FD devices are not powered.

1.7.9 CAN HIGH PIN (CANH)

The CANH output drives the high side of the CAN differential bus. This pin is also tied internally to the receive input comparator. CANH disconnects from the bus when the MCP2557FD/8FD devices are not powered.

1.7.10 SILENT MODE INPUT PIN (S)

This pin sets Normal or Silent mode. In Silent mode, the transmitter is off and the high-speed receiver is active. The CAN bus common mode voltage is $V_{DD}/2$ when in Silent mode.

The 'S' pin (pin 8) is connected to an internal MOS pull-up resistor to V_{DD} or V_{IO} , in the MCP2557FD or MCP2558FD, respectively. The value of the MOS pull-up resistor depends on the supply voltage. Typical values are 660 k Ω for 5V, 1.1 M Ω for 3.3V and 4.4 M Ω for 1.8V

1.7.11 EXPOSED THERMAL PAD (EP)

It is recommended to connect this pad to V_{SS} to enhance electromagnetic immunity and thermal resistance.

MCP2557FD/8FD

1.8 TYPICAL APPLICATION

Figure 1-2 shows a typical application for the MCP2557FD with the NC pin and a split termination.

Figure 1-3 illustrates a typical application for the MCP2558FD.

FIGURE 1-2: MCP2557FD WITH NC AND SPLIT TERMINATION

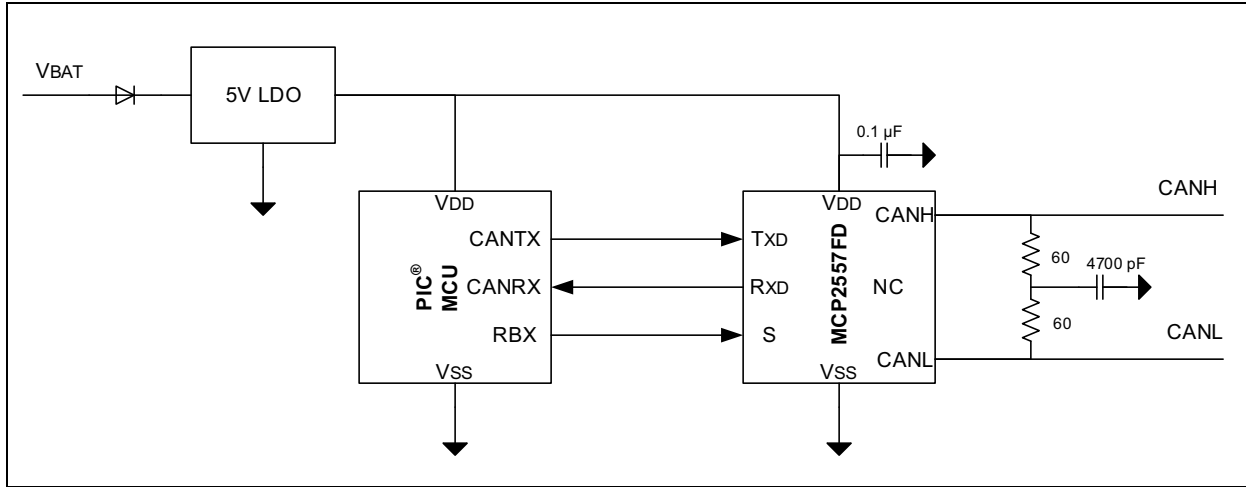
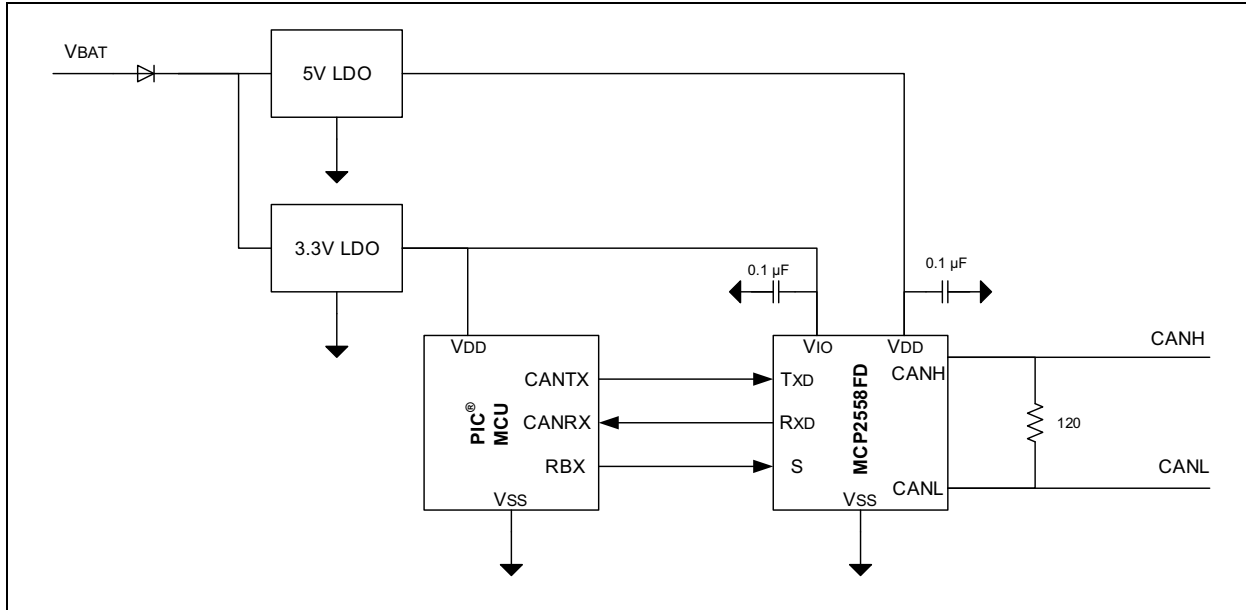

FIGURE 1-3: MCP2558FD WITH V_{IO} PIN



2.0 ELECTRICAL CHARACTERISTICS

2.1 Terms and Definitions

A number of terms are defined in ISO/DIS-11898 that are used to describe the electrical characteristics of a CAN transceiver device. These terms and definitions are summarized in this section.

2.1.1 BUS VOLTAGE

V_{CANL} and V_{CANH} denote the voltages of the bus line wires CANL and CANH relative to the ground of each individual CAN node.

2.1.2 COMMON MODE BUS VOLTAGE RANGE

Boundary voltage levels of V_{CANL} and V_{CANH} with respect to ground, for which proper operation will occur, if the maximum number of CAN nodes are connected to the bus.

2.1.3 DIFFERENTIAL INTERNAL CAPACITANCE, C_{DIFF} (OF A CAN NODE)

Capacitance seen between CANL and CANH during the Recessive state when the CAN node is disconnected from the bus (see [Figure 2-1](#)).

2.1.4 DIFFERENTIAL INTERNAL RESISTANCE, R_{DIFF} (OF A CAN NODE)

Resistance seen between CANL and CANH during the Recessive state when the CAN node is disconnected from the bus (see [Figure 2-1](#)).

2.1.5 DIFFERENTIAL VOLTAGE, V_{DIFF} (OF CAN BUS)

Differential voltage of the two-wire CAN bus, with value equal to $V_{DIFF} = V_{CANH} - V_{CANL}$.

2.1.6 INTERNAL CAPACITANCE, C_{IN} (OF A CAN NODE)

Capacitance seen between CANL (or CANH) and ground during the Recessive state when the CAN node is disconnected from the bus (see [Figure 2-1](#)).

2.1.7 INTERNAL RESISTANCE, R_{IN} (OF A CAN NODE)

Resistance seen between CANL (or CANH) and ground during the Recessive state when the CAN node is disconnected from the bus (see [Figure 2-1](#)).

FIGURE 2-1: PHYSICAL LAYER DEFINITIONS

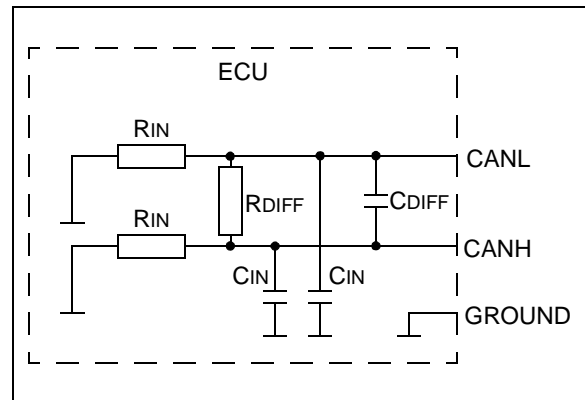

MCP2557FD/8FD

2.2 Absolute Maximum Ratings†

VDD.....	7.0V
VIO.....	7.0V
DC Voltage at TXD, RXD, S and VSS.....	-0.3V to VIO + 0.3V
DC Voltage at CANH, and CANL	-58V to +58V
Transient Voltage on CANH, and CANL (ISO/DIS-7637) (Figure 2-5)	-150V to +100V
Differential Bus Input Voltage VDIFF(I) (t = 60 days, continuous).....	-5V to +10V
Differential Bus Input Voltage VDIFF(I) (1000 pulses, t = 0.1 ms, VCANH = +18V).....	+17V
Dominant State Detection VDIFF(I) (10000 pulses, t = 1 ms).....	+9V
Storage temperature	-55°C to +150°C
Operating ambient temperature	-40°C to +150°C
Virtual Junction Temperature, TVJ (IEC60747-1)	-40°C to +190°C
Soldering temperature of leads (10 seconds)	+300°C
ESD protection on CANH and CANL pins (IEC 61000-4-2)	±13 kV
ESD protection on CANH and CANL pins (IEC 801; Human Body Model).....	±8 kV
ESD protection on all other pins (IEC 801; Human Body Model).....	±4 kV
ESD protection on all pins (IEC 801; Machine Model)	±400V
ESD protection on all pins (IEC 801; Charge Device Model)	±750V

† **Notice:** Stresses above those listed under “Maximum ratings” may cause permanent damage to the device. This is a stress rating only and functional operation of the device at those or any other conditions above those indicated in the operational listings of this specification is not implied. Exposure to maximum rating conditions for extended periods may affect device reliability.

MCP2557FD/8FD

TABLE 2-1: DC CHARACTERISTICS

DC Specifications	Electrical Characteristics: Unless otherwise indicated, T _{AMB} = -40°C to +150°C; V _{DD} = 4.5V to 5.5V, V _{IO} = 1.7V to 5.5V (Note 2), R _L = 60Ω, C _L = 100 pF; unless otherwise specified.					
Parameter	Sym.	Min.	Typ.	Max.	Units	Conditions
Supply						
VDD Pin						
Voltage Range	V _{DD}	4.5	—	5.5	V	
Supply Current	I _{DD}	—	2.5	5	mA	Recessive; V _{TXD} = V _{DD}
		—	55	70		Dominant; V _{TXD} = 0V
Silent Current	I _{DDS}	—	1	3	mA	MCP2557FD
		—	1	3		MCP2558FD Includes I _{IO}
Maximum Supply Current	I _{DDMAX}	—	95	140	mA	Fault condition: V _{TXD} = V _{SS} ; V _{CANH} = V _{CANL} = -5V to +18V
High Level of the POR Comparator for V _{DD}	V _{PORH}	—	3.0	3.95	V	Note 1
Low Level of the POR Comparator for V _{DD}	V _{PORL}	1.0	2.0	3.2	V	Note 1
Hysteresis of POR Comparator for V _{DD}	V _{PORD}	0.2	0.9	2.0	V	Note 1
High Level of the UV Comparator for V _{DD}	V _{UVH}	4.0	4.25	4.4	V	
Low Level of the UV Comparator for V _{DD}	V _{UVL}	3.6	3.8	4.0	V	
Hysteresis of UV comparator	V _{UVDP}	—	0.4	—	V	Note 1
VIO Pin						
Digital Supply Voltage Range	V _{IO}	1.7	—	5.5	V	
Supply Current on V _{IO}	I _{IO}	—	7	30	μA	Recessive; V _{TXD} = V _{IO}
		—	200	400		Dominant; V _{TXD} = 0V
High Level of the POR Comparator for V _{IO}	V _{PORH_VIO}	0.8	1.2	1.7	V	
Low Level of the POR Comparator for V _{IO}	V _{PORL_VIO}	0.7	1.1	1.4	V	
Hysteresis of POR Comparator for V _{IO}	V _{PORD_VIO}	—	0.2	—	V	
Bus Line (CANH; CANL) Transmitter						
CANH; CANL: Recessive Bus Output Voltage	V _{O(R)}	2.0	0.5 V _{DD}	3.0	V	V _{TXD} = V _{DD} ; No load
Recessive Output Current	I _{O(R)}	-5	—	+5	mA	-24V < V _{CAN} < +24V
CANH: Dominant Output Voltage	V _{O(D)}	2.75	3.50	4.50	V	T _{XD} = 0; R _L = 50 to 65Ω
CANL: Dominant Output Voltage		0.50	1.50	2.25		R _L = 50Ω to 65Ω
Driver Symmetry (V _{CANH} +V _{CANL})/V _{DD}	V _{SYM}	0.9	1.0	1.1	V	1 MHz square wave, Recessive and Dominant states, and transition (Note 1)

Note 1: Characterized; not 100% tested.

Note 2: Only MCP2558FD has a V_{IO} pin. For MCP2557FD, V_{IO} is internally connected to V_{DD}.

Note 3: -12V to 12V is ensured by characterization, and tested from -2V to 7V.

MCP2557FD/8FD

TABLE 2-1: DC CHARACTERISTICS (CONTINUED)

DC Specifications		Electrical Characteristics: Unless otherwise indicated, T _{AMB} = -40°C to +150°C; V _{DD} = 4.5V to 5.5V, V _{IO} = 1.7V to 5.5V (Note 2), R _L = 60Ω, C _L = 100 pF; unless otherwise specified.				
Parameter	Sym.	Min.	Typ.	Max.	Units	Conditions
Dominant: Differential Output Voltage	VO(DIFF)(D)	1.5	2.0	3.0	V	V _{TXD} = V _{SS} ; R _L = 50Ω to 65Ω (Figure 2-2, Figure 2-4) (Note 1)
		1.4	2.0	3.0		V _{TXD} = V _{SS} ; R _L = 45Ω to 70Ω (Figure 2-2, Figure 2-4, Section 3) (Note 1)
		1.3	2.0	3.0		V _{TXD} = V _{SS} ; R _L = 40Ω to 75Ω (Figure 2-2, Figure 2-4, Section 3)
		1.5	—	5.0		V _{TXD} = V _{SS} ; R _L = 2240Ω (Figure 2-2, Figure 2-4, Section 3) (Note 1)
Recessive: Differential Output Voltage	VO(DIFF)(R)	-500	0	50	mV	V _{TXD} = V _{DD} , no load (Figure 2-2, Figure 2-4)
CANH: Short-Circuit Output Current	Io(SC)	-115	-85	—	mA	V _{TXD} = V _{SS} ; V _{CANH} = -3V; CANL: floating
CANL: Short Circuit Output Current		—	75	+115	mA	V _{TXD} = V _{SS} ; V _{CANL} = +18V; CANH: floating
Bus Line (CANH; CANL) Receiver						
Recessive Differential Input Voltage	V _{DIFF(R)} (I)	-4.0	—	+0.5	V	-12V < V(CANH, CANL) < +12V; see Figure 2-6 (Note 3)
Dominant Differential Input Voltage	V _{DIFF(D)} (I)	0.9	—	9.0	V	-12V < V(CANH, CANL) < +12V; see Figure 2-6 (Note 3)
Differential Receiver Threshold	V _{TH} (DIFF)	0.5	0.7	0.9	V	-12V < V(CANH, CANL) < +12V; see Figure 2-6 (Note 3)
Differential Input Hysteresis	V _{HYS} (DIFF)	30	—	200	mV	See Figure 2-6, (Note 1)
Single Ended Input Resistance	R _{CAN_H} , R _{CAN_L}	6	—	50	kΩ	Note 1
Internal Resistance Matching $mR = 2 * (R_{CANH} - R_{CANL}) / (R_{CANH} + R_{CANL})$	mR	-3	0	+3	%	V _{CANH} = V _{CANL} (Note 1)
Differential Input Resistance	R _{DIFF}	12	25	100	kΩ	Note 1
Internal Capacitance	C _{IN}	—	20	—	pF	1 Mbps (Note 1)
Differential Internal Capacitance	C _{DIFF}	—	10	—	pF	1 Mbps (Note 1)
CANH, CANL: Input Leakage	I _{LI}	-5	—	+5	μA	V _{DD} = V _{TXD} = V _S = 0V. For MCP2558FD, V _{IO} = 0V. V _{CANH} = V _{CANL} = 5 V.
Digital Input Pins (TxD, S)						
High-Level Input Voltage	V _{IH}	2.0	—	V _{DD} + 0.3	V	MCP2557FD
		0.7 V _{IO}	—	V _{IO} + 0.3		MCP2558FD

Note 1: Characterized; not 100% tested.

Note 2: Only MCP2558FD has a V_{IO} pin. For MCP2557FD, V_{IO} is internally connected to V_{DD}.

Note 3: -12V to 12V is ensured by characterization, and tested from -2V to 7V.

TABLE 2-1: DC CHARACTERISTICS (CONTINUED)

DC Specifications		Electrical Characteristics: Unless otherwise indicated, T _{AMB} = -40°C to +150°C; V _{DD} = 4.5V to 5.5V, V _{IO} = 1.7V to 5.5V (Note 2), R _L = 60Ω, C _L = 100 pF; unless otherwise specified.				
Parameter	Sym.	Min.	Typ.	Max.	Units	Conditions
Low-Level Input Voltage	V _{IL}	-0.3	—	0.8	V	MCP2557FD
		-0.3	—	0.3V _{IO}		MCP2558FD
High-Level Input Current	I _{IH}	-1	—	+1	μA	
TXD: Low-Level Input Current	I _{IL(TXD)}	-270	-150	-30	μA	
S: Low-Level Input Current	I _{IL(S)}	-30	—	-1	μA	
Receive Data (RXD) Output						
High-Level Output Voltage	V _{OH}	V _{DD} - 0.4	—	—	V	MCP2557FD: I _{OH} = -2 mA; typical -4 mA
		V _{IO} - 0.4	—	—		MCP2558FD: V _{IO} = 2.7V to 5.5V, I _{OH} = -1 mA; V _{IO} = 1.7V to 2.7V, I _{OH} = -0.5 mA, typical -2 mA
Low-Level Output Voltage	V _{OL}	—	—	0.4	V	I _{OL} = 4 mA; typical 8 mA
Thermal Shutdown						
Shutdown Junction Temperature	T _{J(SD)}	165	175	185	°C	-12V < V(CANH, CANL) < +12V (Note 1)
Shutdown Temperature Hysteresis	T _{J(HYST)}	15	—	30	°C	-12V < V(CANH, CANL) < +12V (Note 1)

Note 1: Characterized; not 100% tested.

2: Only MCP2558FD has a V_{IO} pin. For MCP2557FD, V_{IO} is internally connected to V_{DD}.

3: -12V to 12V is ensured by characterization, and tested from -2V to 7V.

MCP2557FD/8FD

FIGURE 2-2: PHYSICAL BIT REPRESENTATION AND SIMPLIFIED BIAS IMPLEMENTATION

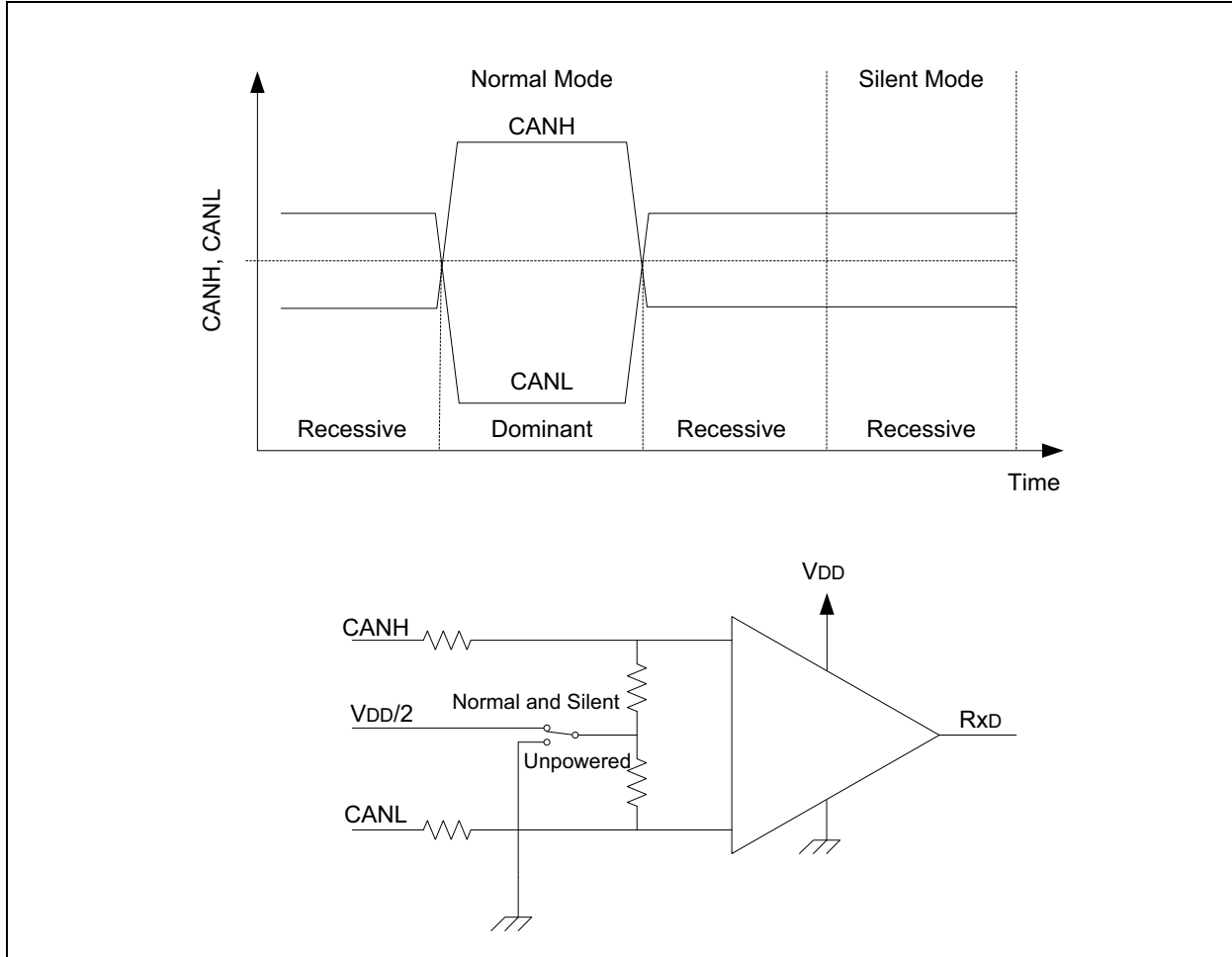

TABLE 2-2: AC CHARACTERISTICS

AC Characteristics		Electrical Characteristics: Unless otherwise indicated, $T_{AMB} = -40^{\circ}\text{C}$ to $+150^{\circ}\text{C}$; $V_{DD} = 4.5\text{V}$ to 5.5V , $V_{IO} = 1.7\text{V}$ to 5.5V (Note 2), $R_L = 60\Omega$, $C_L = 100\text{pF}$. Maximum $V_{DIFF(D)}(I) = 3\text{V}$.					
Param. No.	Parameter	Sym.	Min.	Typ.	Max.	Units	Conditions
1	Bit Time	t _{BIT}	0.125	—	69.44	μs	
2	Nominal Bit Rate	NBR	14.4	—	8000	kbps	
3	Delay TXD Low to Bus Dominant	t _{TXD-BUSON}	—	50	85	ns	Note 1
4	Delay TXD High to Bus Recessive	t _{TXD-BUSOFF}	—	40	85	ns	Note 1
5	Delay Bus Dominant to RXD	t _{BUSON-RXD}	—	70	85	ns	Note 1
6	Delay Bus Recessive to RXD	t _{BUSOFF-RXD}	—	110	145	ns	Note 1

Note 1: Characterized, not 100% tested.

2: Not in ISO/DIS-11898-2:2015, but needs to be characterized.

TABLE 2-2: AC CHARACTERISTICS (CONTINUED)

AC Characteristics		Electrical Characteristics: Unless otherwise indicated, T _{AMB} = -40°C to +150°C; V _{DD} = 4.5V to 5.5V, V _{IO} = 1.7V to 5.5V (Note 2), R _L = 60Ω, C _L = 100 pF. Maximum V _{DIFF(D)} (I) = 3V.					
Param. No.	Parameter	Sym.	Min.	Typ.	Max.	Units	Conditions
7	Propagation Delay TXD to RXD Worst Case of t _{LOOP(R)} and t _{LOOP(F)} Figure 2-9	t _{TXD - RXD}	—	90	120	ns	R _L = 150Ω, C _L = 200 pF (Note 1)
			—	115	150		
7a	Propagation Delay, Rising Edge	t _{LOOP(R)}	—	90	120	ns	
7b	Propagation Delay, Falling Edge	t _{LOOP(F)}	—	80	120	ns	
8a	Recessive Bit Time on RXD – 1 Mbps, Loop Delay Symmetry (Note 2)	t _{BIT(RXD), 1M}	900	985	1100	ns	t _{BIT(TXD)} = 1000 ns (Figure 2-9)
			800	960	1255		t _{BIT(TXD)} = 1000 ns (Figure 2-9), R _L = 150Ω, C _L = 200 pF (Note 1)
8b	Recessive Bit Time on RXD – 2 Mbps, Loop Delay Symmetry	t _{BIT(RXD), 2M}	450	490	550	ns	t _{BIT(TXD)} = 500 ns (Figure 2-9)
			400	460	550		t _{BIT(TXD)} = 500 ns (Figure 2-9), R _L = 150Ω, C _L = 200 pF (Note 1)
8c	Recessive Bit Time on RXD – 5 Mbps, Loop Delay Symmetry	t _{BIT(RXD), 5M}	160	190	220	ns	t _{BIT(TXD)} = 200 ns (Figure 2-9)
8d	Recessive Bit Time on RXD – 8 Mbps, Loop Delay Symmetry (Note 2)	t _{BIT(RXD), 8M}	85	100	135	ns	t _{BIT(TXD)} = 120 ns (Figure 2-9) (Note 1)
10	Delay Silent to Normal Mode	t _{WAKE}	—	7	30	μs	Negative edge on S
11	Permanent Dominant Detect Time	t _{PDT}	0.8	1.9	5	ms	T _{XD} = 0V
12	Permanent Dominant Timer Reset	t _{PDTR}	—	5	—	ns	The shortest recessive pulse on TXD or CAN bus to reset Permanent Dominant Timer
13a	Transmitted Bit Time on Bus – 1 Mbps (Note 2)	t _{BIT(BUS), 1M}	870	1000	1060	ns	t _{BIT(TXD)} = 1000 ns (Figure 2-9)
			870	1000	1060		t _{BIT(TXD)} = 1000 ns (Figure 2-9), R _L = 150Ω, C _L = 200 pF (Note 1)
13b	Transmitted Bit Time on Bus – 2 Mbp	t _{BIT(BUS), 2M}	435	515	530	ns	t _{BIT(TXD)} = 500 ns (Figure 2-9)
			435	480	550		t _{BIT(TXD)} = 500 ns (Figure 2-9) R _L = 150Ω, C _L = 200 pF (Note 1)

Note 1: Characterized, not 100% tested.

2: Not in ISO/DIS-11898-2:2015, but needs to be characterized.

MCP2557FD/8FD

TABLE 2-2: AC CHARACTERISTICS (CONTINUED)

AC Characteristics		Electrical Characteristics: Unless otherwise indicated, T _{AMB} = -40°C to +150°C; V _{DD} = 4.5V to 5.5V, V _{IO} = 1.7V to 5.5V (Note 2), R _L = 60Ω, C _L = 100 pF. Maximum V _{DIFF(D)} (I) = 3V.					
Param. No.	Parameter	Sym.	Min.	Typ.	Max.	Units	Conditions
13c	Transmitted Bit Time on Bus – 5 Mbps	t _{BIT} (BUS), 5M	155	200	210	ns	t _{BIT} (TXD) = 200 ns (Figure 2-9) (Note 1)
13d	Transmitted Bit Time on Bus - 8Mbps (Note 2)	t _{BIT} (BUS), 8M	100	125	140	ns	t _{BIT} (TXD) = 120 ns (Figure 2-9) (Note 1)
14a	Receiver Timing Symmetry – 1 Mbps (Note 2)	t _{DIFF} (REC), 1M = t _{BIT} (RXD)	-65	0	40	ns	t _{BIT} (TXD) = 1000 ns (Figure 2-9)
		- t _{BIT} (BUS)	-130	0	80		t _{BIT} (TXD) = 1000 ns (Figure 2-9), R _L = 150Ω, C _L = 200 pF (Note 1)
14b	Receiver Timing Symmetry – 2 Mbps	t _{DIFF} (REC), 2M	-65	0	40	ns	t _{BIT} (TXD) = 500 ns (Figure 2-9)
			-70	0	40		t _{BIT} (TXD) = 500 ns (Figure 2-9), R _L = 150Ω, C _L = 200 pF (Note 1)
14c	Receiver Timing Symmetry – 5 Mbps	t _{DIFF} (REC), 5M	-45	0	15	ns	t _{BIT} (TXD) = 200 ns (Figure 2-9) (Note 1)
14d	Receiver Timing Symmetry – 8 Mbps (Note 2)	t _{DIFF} (REC), 8M	-45	0	10	ns	t _{BIT} (TXD) = 120 ns (Figure 2-9) (Note 1)

Note 1: Characterized, not 100% tested.

2: Not in ISO/DIS-11898-2:2015, but needs to be characterized.

FIGURE 2-3: TEST LOAD CONDITIONS

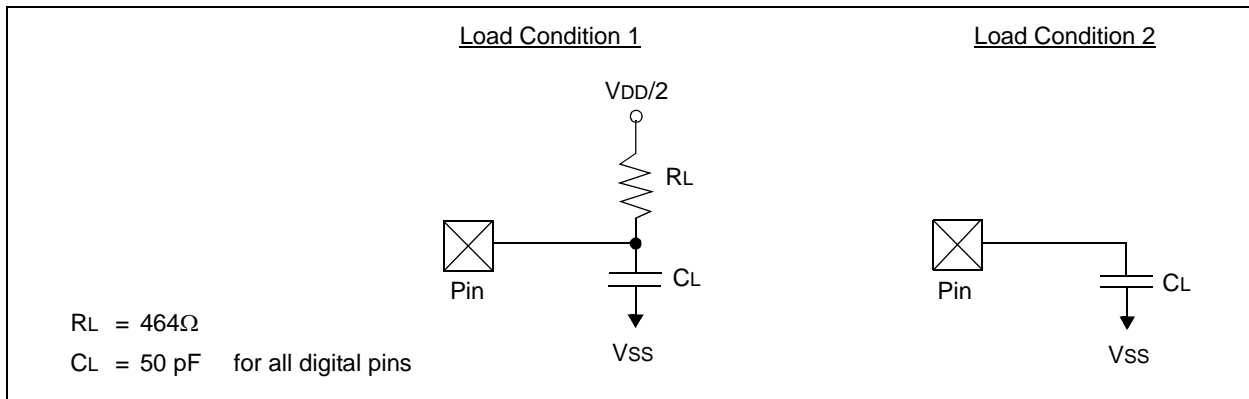

FIGURE 2-4: TEST CIRCUIT FOR ELECTRICAL CHARACTERISTICS

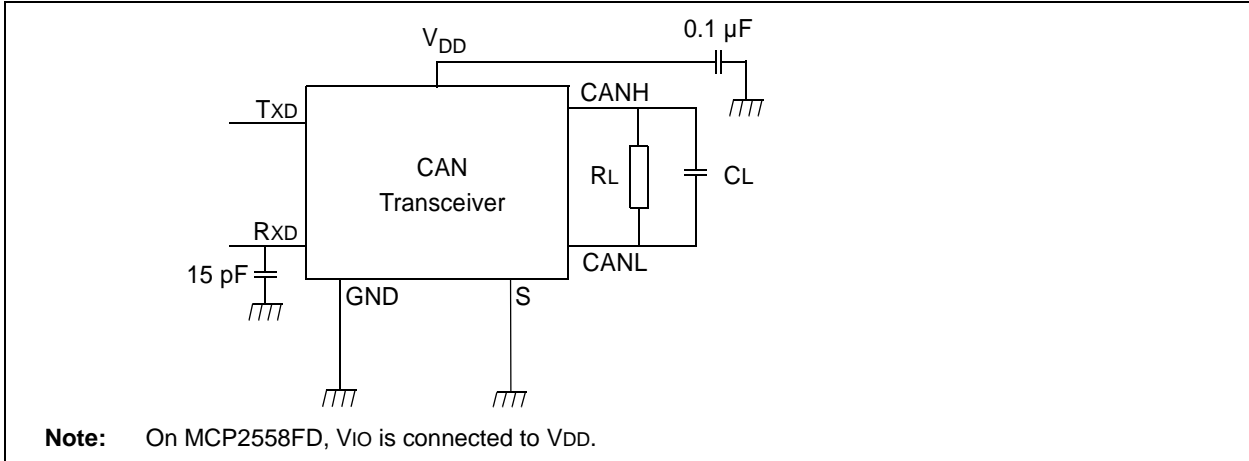

FIGURE 2-5: TEST CIRCUIT FOR AUTOMOTIVE TRANSIENTS

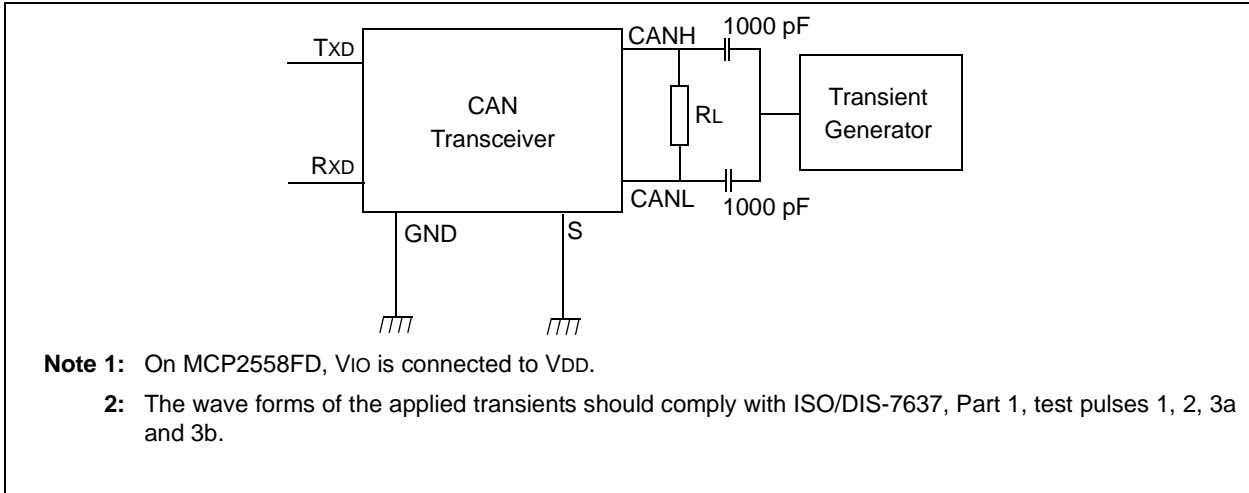
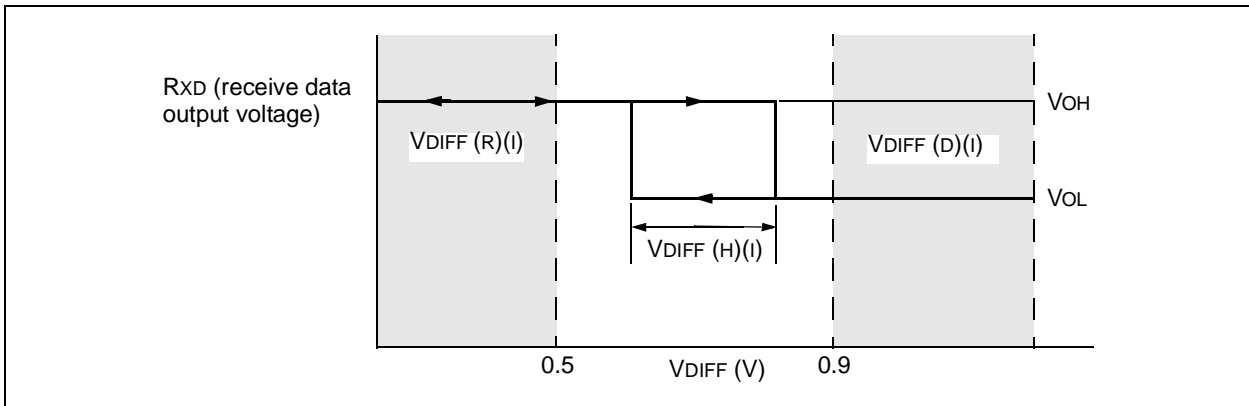

FIGURE 2-6: HYSTERESIS OF THE RECEIVER



MCP2557FD/8FD

2.3 Timing Diagrams and Specifications

FIGURE 2-7: TIMING DIAGRAM FOR AC CHARACTERISTICS

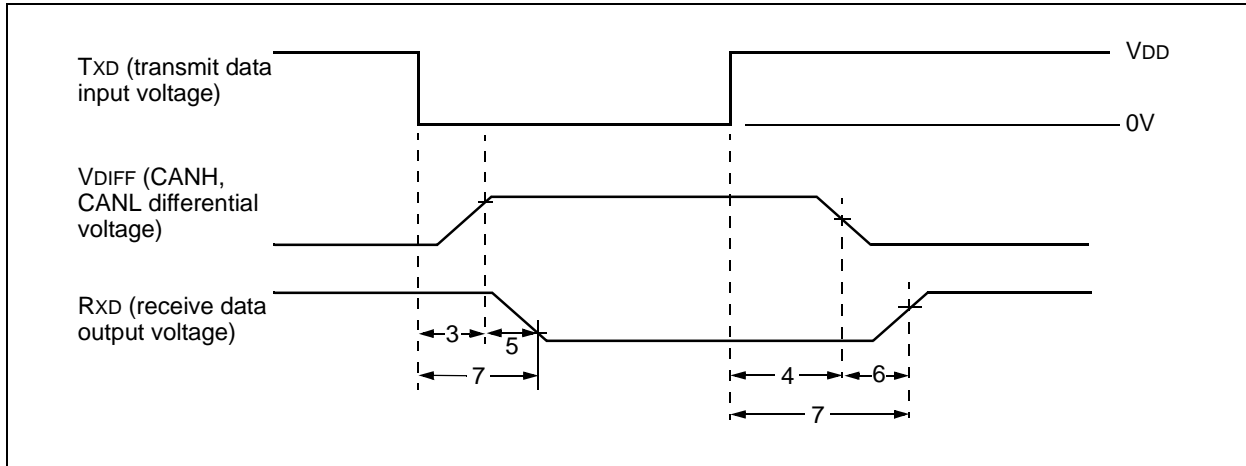

FIGURE 2-8: PERMANENT DOMINANT TIMER RESET DETECT

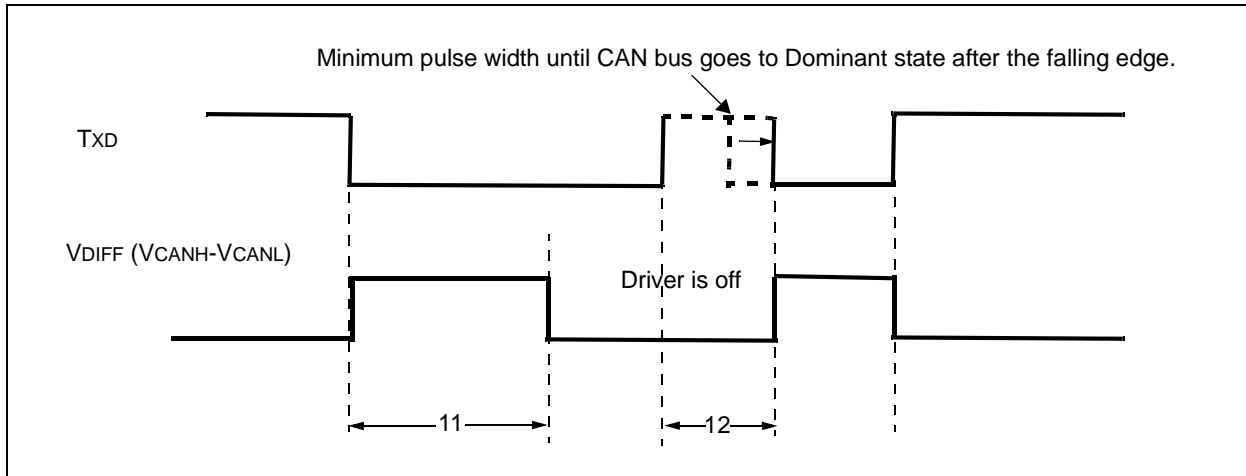
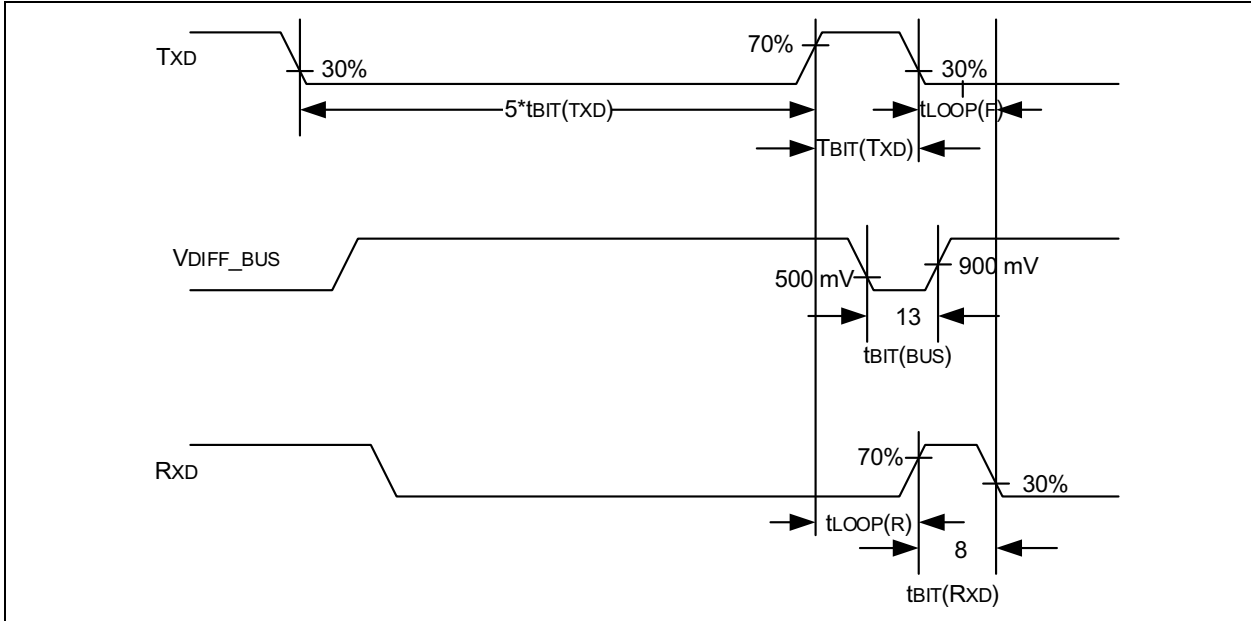

FIGURE 2-9: TIMING DIAGRAM FOR LOOP DELAY SYMMETRY



2.4 Thermal Specifications

Parameter	Sym.	Min.	Typ.	Max.	Units
Temperature Ranges					
Specified Temperature Range	T _A	-40	—	+150	°C
Operating Temperature Range	T _A	-40	—	+150	°C
Storage Temperature Range	T _A	-65	—	+155	°C
Package Thermal Resistances					
Thermal Resistance, 8LD DFN (3x3)	θ _{JA}	—	56.7	—	°C/W
Thermal Resistance, 8LD SOIC	θ _{JA}	—	149.5	—	°C/W
Thermal Resistance, 8LD TDFN (2x3)	θ _{JA}	—	53	—	°C/W

MCP2557FD/8FD

3.0 TYPICAL PERFORMANCE CURVES

Note: The graphs and tables provided following this note are a statistical summary based on a limited number of samples and are provided for informational purposes only. The performance characteristics listed herein are not tested or guaranteed. In some graphs or tables, the data presented may be outside the specified operating range (e.g., outside specified power supply range) and therefore outside the warranted range.

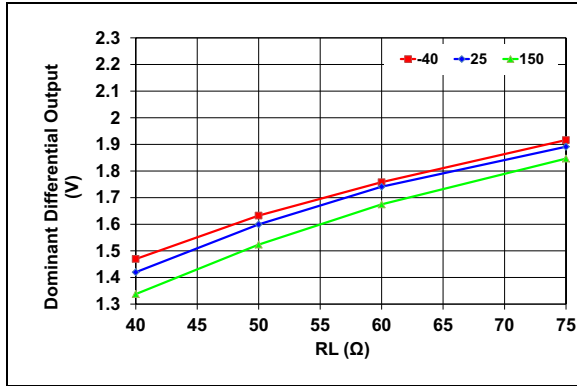

FIGURE 3-1: Dominant Differential Output vs. RL ($V_{DD} = 4.5V$).

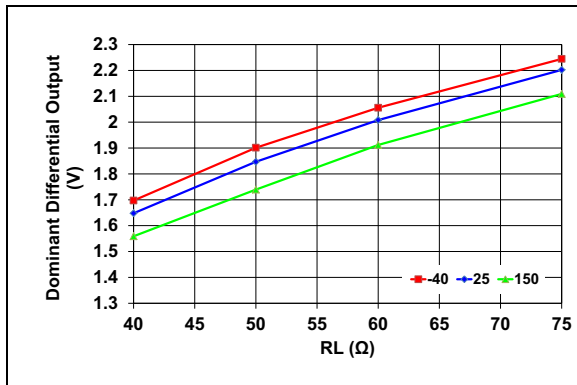

FIGURE 3-2: Dominant Differential Output vs. RL ($V_{DD} = 5.0V$).

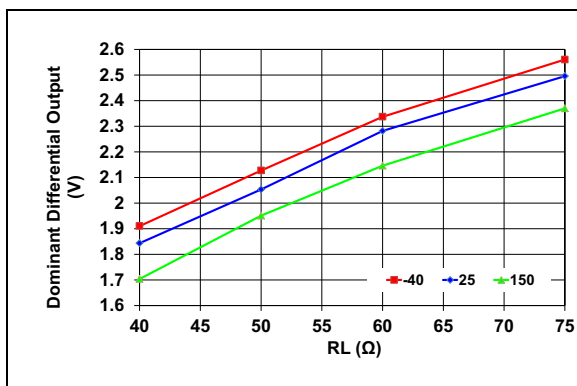
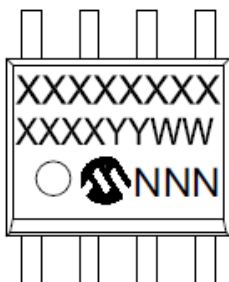

FIGURE 3-3: Dominant Differential Output vs. RL ($V_{DD} = 5.5V$).

4.0 PACKAGING INFORMATION

4.1 Package Marking Information

8-Lead SOIC (150 mil)



Part Number	Code
MCP2557FDT-H/SN	MCP2557
MCP2557FD-H/SN	MCP2557
MCP2558FDT-H/SN	MCP2558
MCP2558FD-H/SN	MCP2558

Example:

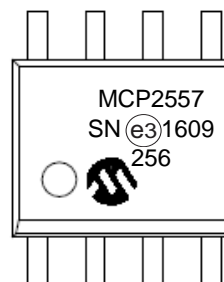

8-Lead TDFN (02x03x0.8 mm)



Part Number	Code
MCP2557FDT-H/MNY	ACZ
MCP2558FDT-H/MNY	ADA

Example:

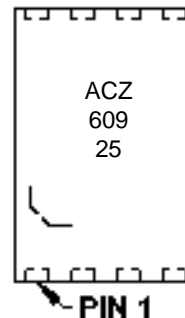

8-Lead DFN (03x03x0.9 mm)



Part Number	Code
MCP2557FDT-H/MF	DAEO
MCP2557FD-H/MF	DAEO
MCP2558FDT-H/MF	DAEQ
MCP2558FD-H/MF	DAEQ

Example:

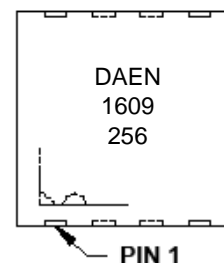

Legend:	XX...X	Customer-specific information
	Y	Year code (last digit of calendar year)
	YY	Year code (last 2 digits of calendar year)
	WW	Week code (week of January 1 is week '01')
	NNN	Alphanumeric traceability code
	(e3)	Pb-free JEDEC® designator for Matte Tin (Sn) This package is Pb-free. The Pb-free JEDEC® designator ((e3) can be found on the outer packaging for this package.

Note: In the event the full Microchip part number cannot be marked on one line, it will be carried over to the next line, thus limiting the number of available characters for customer-specific information.

MCP2557FD/8FD

8-Lead Plastic Small Outline (SN) - Narrow, 3.90 mm Body [SOIC]

Note: For the most current package drawings, please see the Microchip Packaging Specification located at <http://www.microchip.com/packaging>

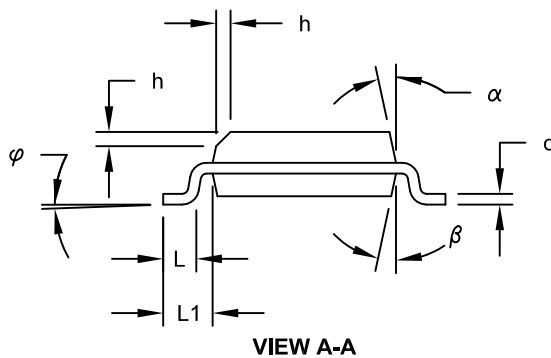
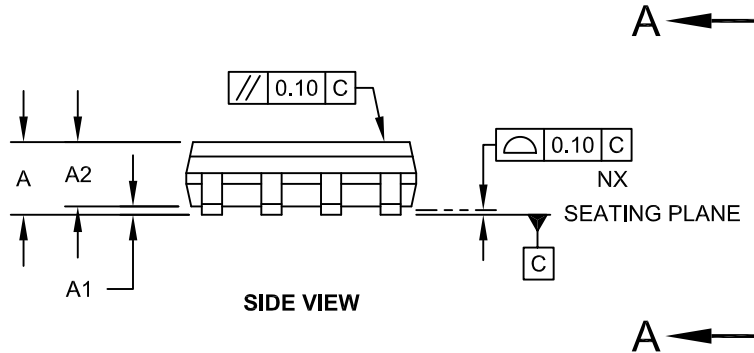
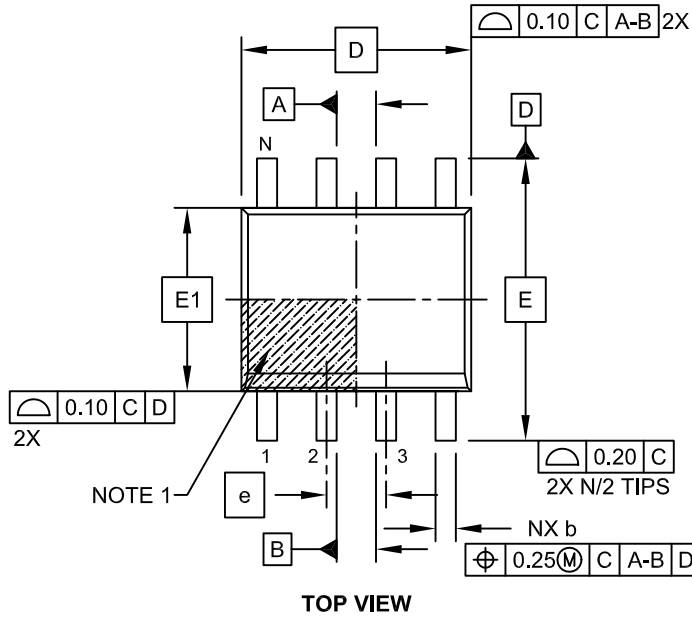

Microchip Technology Drawing No. C04-057C Sheet 1 of 2

8-Lead Plastic Small Outline (SN) - Narrow, 3.90 mm Body [SOIC]

Note: For the most current package drawings, please see the Microchip Packaging Specification located at <http://www.microchip.com/packaging>

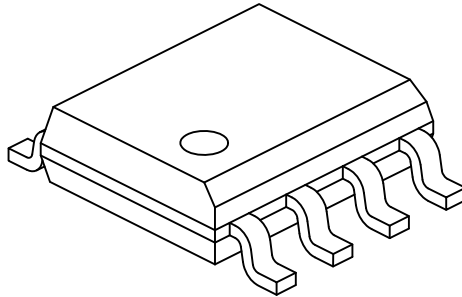

Dimension Limits	Units	MILLIMETERS		
		MIN	NOM	MAX
Number of Pins	N	8		
Pitch	e	1.27 BSC		
Overall Height	A	-	-	1.75
Molded Package Thickness	A2	1.25	-	-
Standoff §	A1	0.10	-	0.25
Overall Width	E	6.00 BSC		
Molded Package Width	E1	3.90 BSC		
Overall Length	D	4.90 BSC		
Chamfer (Optional)	h	0.25	-	0.50
Foot Length	L	0.40	-	1.27
Footprint	L1	1.04 REF		
Foot Angle	φ	0°	-	8°
Lead Thickness	c	0.17	-	0.25
Lead Width	b	0.31	-	0.51
Mold Draft Angle Top	α	5°	-	15°
Mold Draft Angle Bottom	β	5°	-	15°

Notes:

1. Pin 1 visual index feature may vary, but must be located within the hatched area.
2. § Significant Characteristic
3. Dimensions D and E1 do not include mold flash or protrusions. Mold flash or protrusions shall not exceed 0.15mm per side.
4. Dimensioning and tolerancing per ASME Y14.5M
 - BSC: Basic Dimension. Theoretically exact value shown without tolerances.
 - REF: Reference Dimension, usually without tolerance, for information purposes only.

Microchip Technology Drawing No. C04-057C Sheet 2 of 2

MCP2557FD/8FD

8-Lead Plastic Small Outline (SN) – Narrow, 3.90 mm Body [SOIC]

Note: For the most current package drawings, please see the Microchip Packaging Specification located at <http://www.microchip.com/packaging>

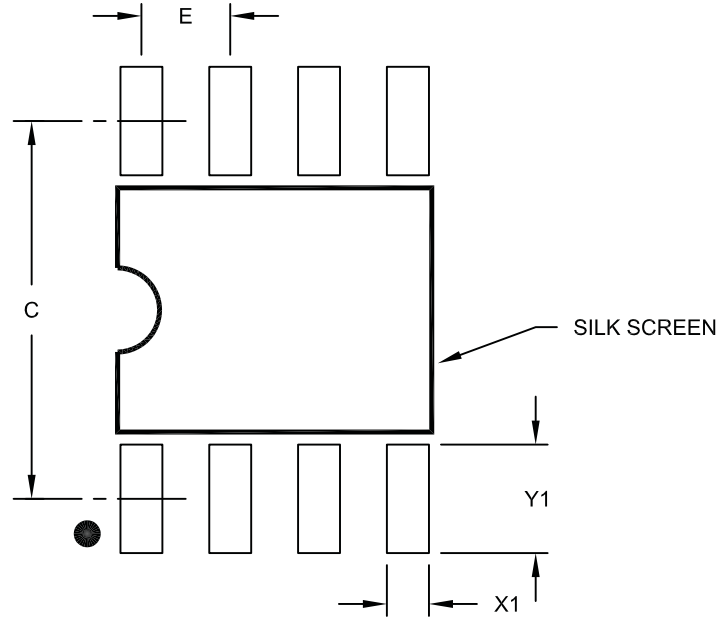

RECOMMENDED LAND PATTERN

		Units	MILLIMETERS		
		Dimension Limits	MIN	NOM	MAX
Contact Pitch	E		1.27 BSC		
Contact Pad Spacing	C			5.40	
Contact Pad Width (X8)	X1				0.60
Contact Pad Length (X8)	Y1				1.55

Notes:

1. Dimensioning and tolerancing per ASME Y14.5M

BSC: Basic Dimension. Theoretically exact value shown without tolerances.

Microchip Technology Drawing No. C04-2057A

8-Lead Plastic Dual Flat, No Lead Package (MN) – 2x3x0.75mm Body [TDFN]

Note: For the most current package drawings, please see the Microchip Packaging Specification located at <http://www.microchip.com/packaging>

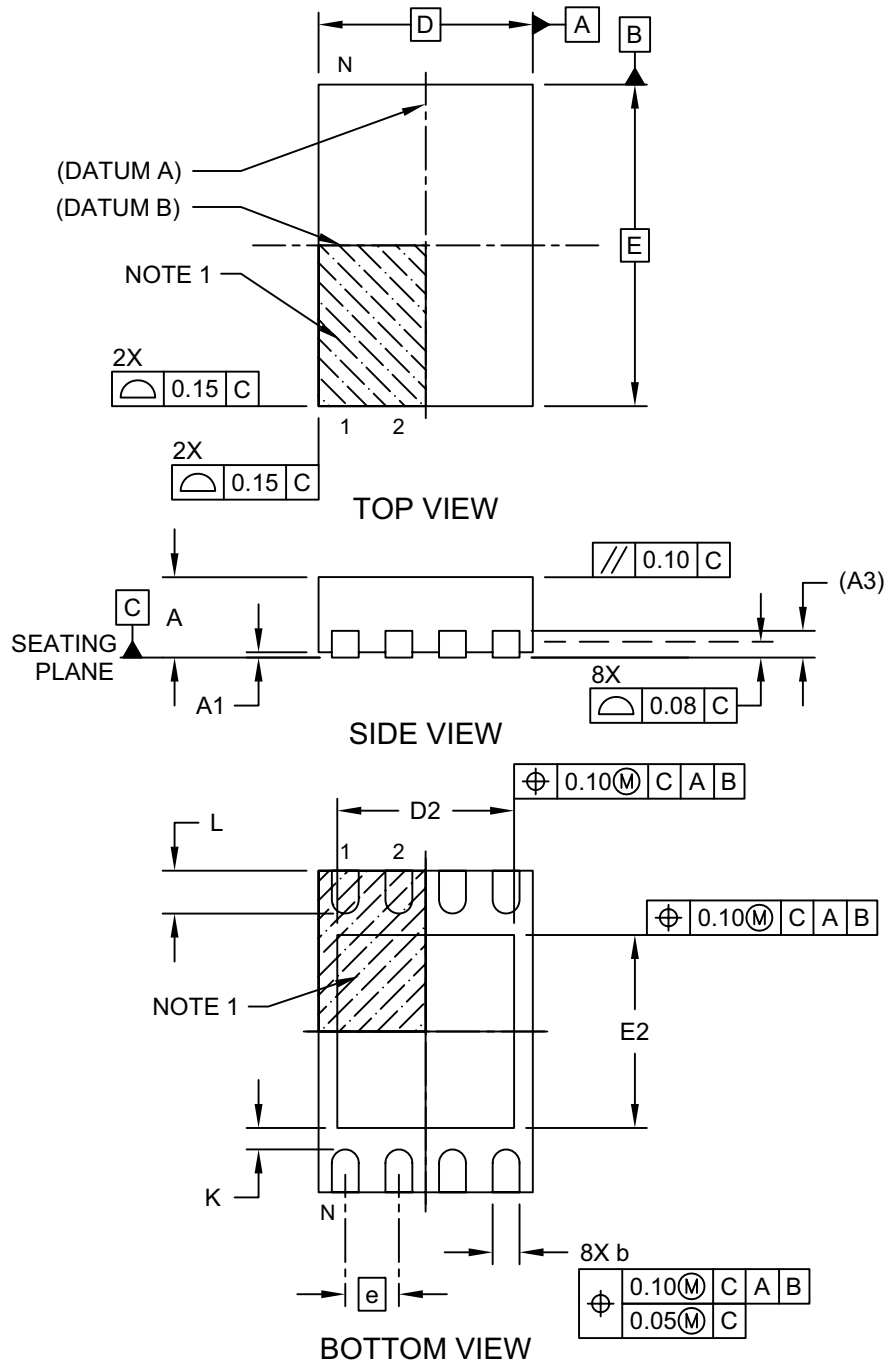

Microchip Technology Drawing No. C04-129-MN Rev D Sheet 2 of 2

MCP2557FD/8FD

8-Lead Plastic Dual Flat, No Lead Package (MN) – 2x3x0.75mm Body [TDFN]

Note: For the most current package drawings, please see the Microchip Packaging Specification located at <http://www.microchip.com/packaging>

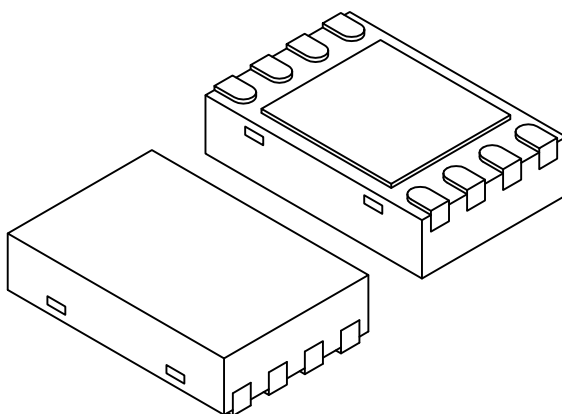

Dimension Limits	Units	MILLIMETERS		
		MIN	NOM	MAX
Number of Pins	N	8		
Pitch	e	0.50 BSC		
Overall Height	A	0.70	0.75	0.80
Standoff	A1	0.00	0.02	0.05
Contact Thickness	A3	0.20 REF		
Overall Length	D	2.00 BSC		
Overall Width	E	3.00 BSC		
Exposed Pad Length	D2	1.45	-	1.65
Exposed Pad Width	E2	1.60	-	1.80
Contact Width	b	0.20	0.25	0.30
Contact Length	L	0.25	0.30	0.45
Contact-to-Exposed Pad	K	0.20	-	-

Notes:

1. Pin 1 visual index feature may vary, but must be located within the hatched area.
2. Package may have one or more exposed tie bars at ends.
3. Package is saw singulated
4. Dimensioning and tolerancing per ASME Y14.5M

BSC: Basic Dimension. Theoretically exact value shown without tolerances.

REF: Reference Dimension, usually without tolerance, for information purposes only.

Microchip Technology Drawing No. C04-129-MN Rev D Sheet 2 of 2

8-Lead Plastic Dual Flat, No Lead Package (MN) – 2x3x0.75mm Body [TDFN]

Note: For the most current package drawings, please see the Microchip Packaging Specification located at <http://www.microchip.com/packaging>

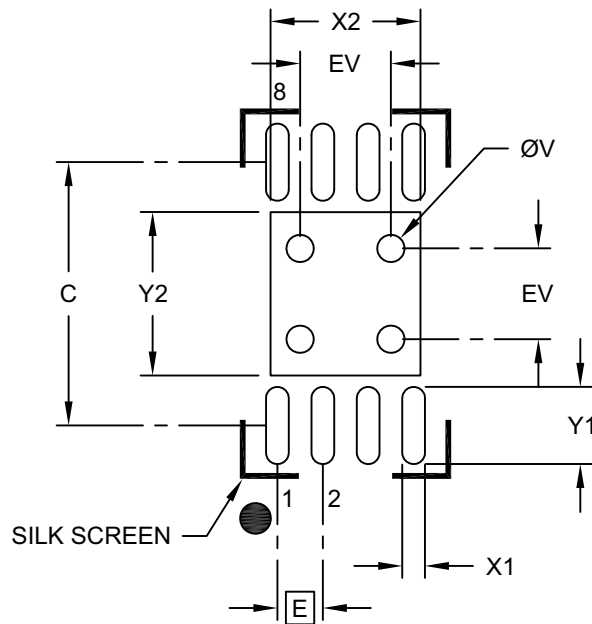

RECOMMENDED LAND PATTERN

Dimension Limits	Units	MILLIMETERS		
		MIN	NOM	MAX
Contact Pitch	E	0.50 BSC		
Optional Center Pad Width	X2			1.65
Optional Center Pad Length	Y2			1.80
Contact Pad Spacing	C		2.90	
Contact Pad Width (X8)	X1			0.25
Contact Pad Length (X8)	Y1			0.85
Thermal Via Diameter	V		0.30	
Thermal Via Pitch	EV		1.00	

Notes:

- Dimensioning and tolerancing per ASME Y14.5M
BSC: Basic Dimension. Theoretically exact value shown without tolerances.
- For best soldering results, thermal vias, if used, should be filled or tented to avoid solder loss during reflow process

Microchip Technology Drawing No. C04-129-MN Rev. A

MCP2557FD/8FD

8-Lead Plastic Dual Flat, No Lead Package (MF) - 3x3x0.9mm Body [DFN]

Note: For the most current package drawings, please see the Microchip Packaging Specification located at <http://www.microchip.com/packaging>

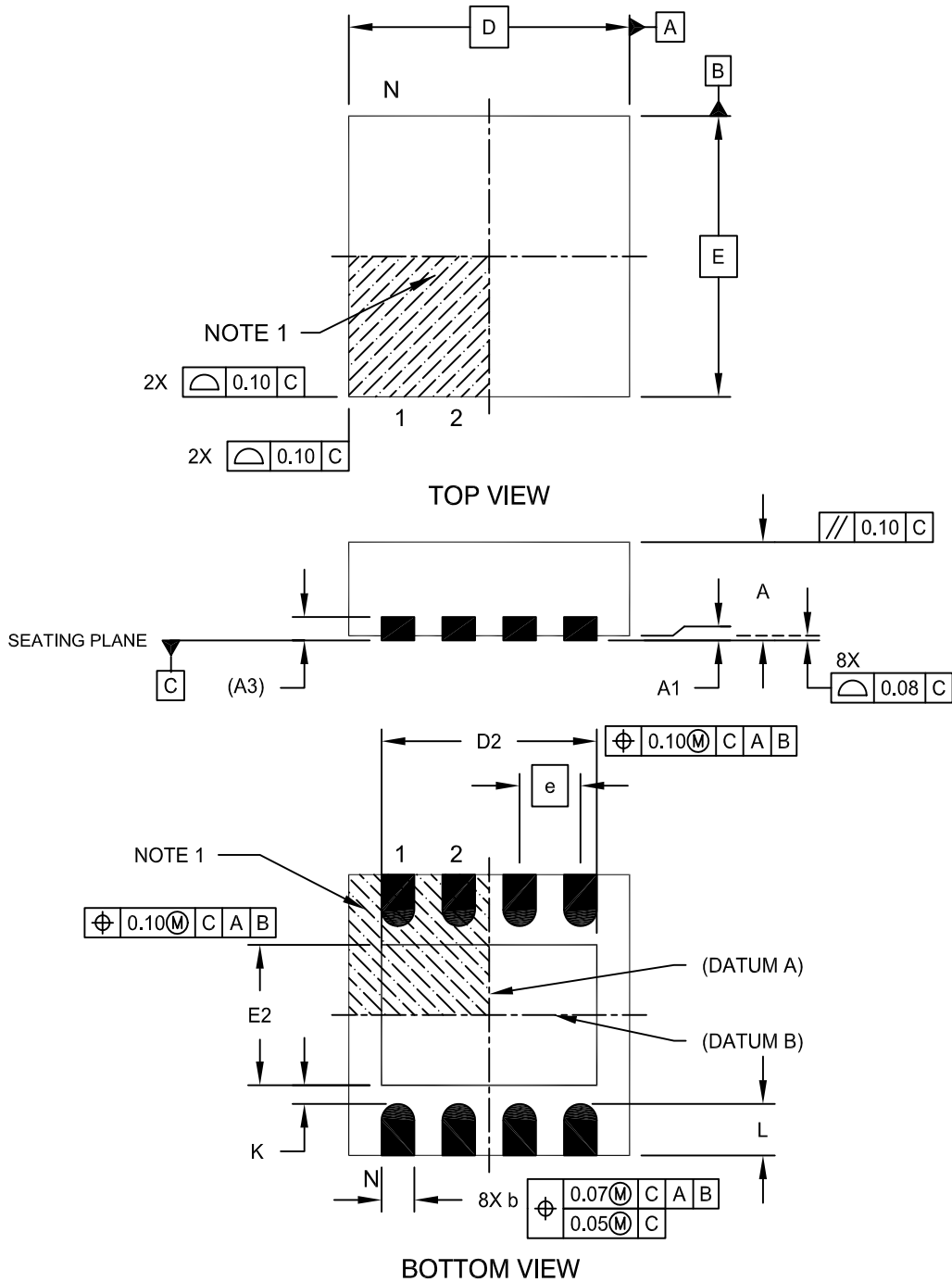

Microchip Technology Drawing No. C04-062C Sheet 1 of 2

MCP2557FD/8FD

8-Lead Plastic Dual Flat, No Lead Package (MF) - 3x3x0.9mm Body [DFN]

Note: For the most current package drawings, please see the Microchip Packaging Specification located at <http://www.microchip.com/packaging>

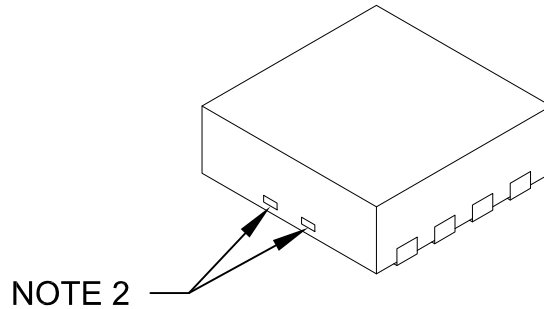

Dimension Limits	Units	MILLIMETERS		
		MIN	NOM	MAX
Number of Pins	N	8		
Pitch	e	0.65 BSC		
Overall Height	A	0.80	0.90	1.00
Standoff	A1	0.00	0.02	0.05
Contact Thickness	A3	0.20 REF		
Overall Length	D	3.00 BSC		
Exposed Pad Width	E2	1.34	-	1.60
Overall Width	E	3.00 BSC		
Exposed Pad Length	D2	1.60	-	2.40
Contact Width	b	0.25	0.30	0.35
Contact Length	L	0.20	0.30	0.55
Contact-to-Exposed Pad	K	0.20	-	-

Notes:

1. Pin 1 visual index feature may vary, but must be located within the hatched area.
2. Package may have one or more exposed tie bars at ends.
3. Package is saw singulated
4. Dimensioning and tolerancing per ASME Y14.5M

BSC: Basic Dimension. Theoretically exact value shown without tolerances.

REF: Reference Dimension, usually without tolerance, for information purposes only.

Microchip Technology Drawing No. C04-062C Sheet 2 of 2

MCP2557FD/8FD

8-Lead Plastic Dual Flat, No Lead Package (MF) - 3x3x0.9mm Body [DFN]

Note: For the most current package drawings, please see the Microchip Packaging Specification located at <http://www.microchip.com/packaging>

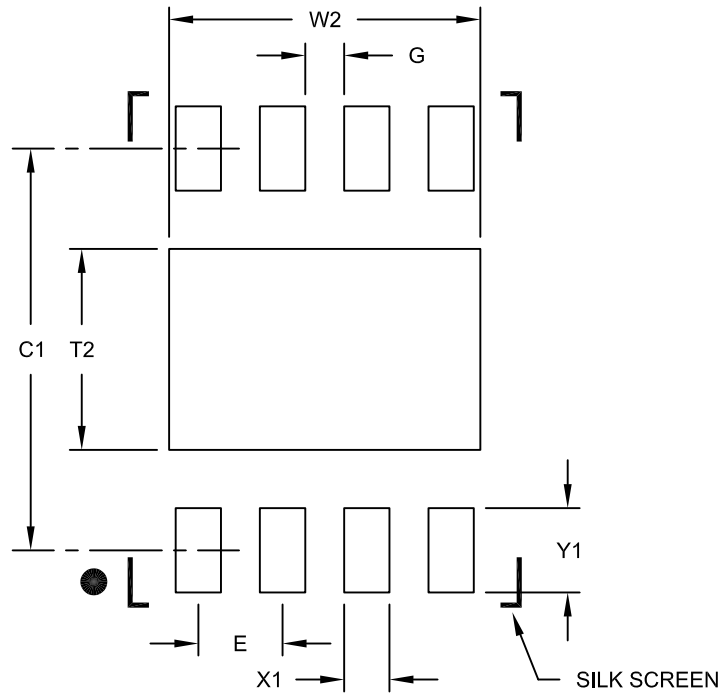

RECOMMENDED LAND PATTERN

Dimension Limits	Units	MILLIMETERS		
		MIN	NOM	MAX
Contact Pitch	E	0.65 BSC		
Optional Center Pad Width	W2			2.40
Optional Center Pad Length	T2			1.55
Contact Pad Spacing	C1		3.10	
Contact Pad Width (X8)	X1			0.35
Contact Pad Length (X8)	Y1			0.65
Distance Between Pads	G	0.30		

Notes:

1. Dimensioning and tolerancing per ASME Y14.5M

BSC: Basic Dimension. Theoretically exact value shown without tolerances.

Microchip Technology Drawing No. C04-2062B

APPENDIX A: REVISION HISTORY

Revision A (March 2016)

Initial release of this document.

MCP2557FD/8FD

NOTES:

PRODUCT IDENTIFICATION SYSTEM

To order or obtain information, e.g., on pricing or delivery, refer to the factory or the listed sales office.

<u>PART NO.</u>	<u>[X]⁽¹⁾</u>	<u>X</u>	<u>/XX</u>	
Device	Tape and Reel Option	Temperature Range	Package	
Device:	MCP2557FD:	CAN FD Transceiver w/No Connect Pin 5		
	MCP2558FD:	CAN FD Transceiver w/Vio Connect Pin 5		
Tape and Reel Option:	Blank = Standard packaging (tube or tray)			
	T = Tape and Reel ⁽¹⁾			
Temperature Range:	H = -40°C to +150°C			
Package:	MF = Plastic Dual Flat No Lead Package – 3x3x0.9 mm Body (DFN), 8-lead			
	MNY = Plastic Dual Flat No Lead Package – 2x3x0.75 mm Body (TDFN), 8-lead			
	SN = Plastic Small Outline (SN) – Narrow, 3.90 mm, Body (SOIC), 8-lead			

Examples:

a) MCP2558FDT-H/MF: Tape and Reel, 8-lead, Plastic Dual Flat No Lead DFN package.

b) MCP2557FD-H/SN: 8-lead, Plastic Small Outline SOIC package.

c) MCP2558FDT-H/MNY: Tape and Reel, 8-lead, Plastic Dual Flat No Lead TDFN package.

Note1: Tape and Reel identifier only appears in the catalog part number description. This identifier is used for ordering purposes and is not printed on the device package. Check with your Microchip Sales Office for package availability with the Tape and Reel option.

MCP2557FD/8FD

NOTES:

Note the following details of the code protection feature on Microchip devices:

- Microchip products meet the specification contained in their particular Microchip Data Sheet.
- Microchip believes that its family of products is one of the most secure families of its kind on the market today, when used in the intended manner and under normal conditions.
- There are dishonest and possibly illegal methods used to breach the code protection feature. All of these methods, to our knowledge, require using the Microchip products in a manner outside the operating specifications contained in Microchip's Data Sheets. Most likely, the person doing so is engaged in theft of intellectual property.
- Microchip is willing to work with the customer who is concerned about the integrity of their code.
- Neither Microchip nor any other semiconductor manufacturer can guarantee the security of their code. Code protection does not mean that we are guaranteeing the product as “unbreakable.”

Code protection is constantly evolving. We at Microchip are committed to continuously improving the code protection features of our products. Attempts to break Microchip's code protection feature may be a violation of the Digital Millennium Copyright Act. If such acts allow unauthorized access to your software or other copyrighted work, you may have a right to sue for relief under that Act.

Information contained in this publication regarding device applications and the like is provided only for your convenience and may be superseded by updates. It is your responsibility to ensure that your application meets with your specifications. MICROCHIP MAKES NO REPRESENTATIONS OR WARRANTIES OF ANY KIND WHETHER EXPRESS OR IMPLIED, WRITTEN OR ORAL, STATUTORY OR OTHERWISE, RELATED TO THE INFORMATION, INCLUDING BUT NOT LIMITED TO ITS CONDITION, QUALITY, PERFORMANCE, MERCHANTABILITY OR FITNESS FOR PURPOSE. Microchip disclaims all liability arising from this information and its use. Use of Microchip devices in life support and/or safety applications is entirely at the buyer's risk, and the buyer agrees to defend, indemnify and hold harmless Microchip from any and all damages, claims, suits, or expenses resulting from such use. No licenses are conveyed, implicitly or otherwise, under any Microchip intellectual property rights unless otherwise stated.

Microchip received ISO/TS-16949:2009 certification for its worldwide headquarters, design and wafer fabrication facilities in Chandler and Tempe, Arizona; Gresham, Oregon and design centers in California and India. The Company's quality system processes and procedures are for its PIC® MCUs and dsPIC® DSCs, KEELoC® code hopping devices, Serial EEPROMs, microperipherals, nonvolatile memory and analog products. In addition, Microchip's quality system for the design and manufacture of development systems is ISO 9001:2000 certified.

QUALITY MANAGEMENT SYSTEM
CERTIFIED BY DNV
== ISO/TS 16949 ==

Trademarks

The Microchip name and logo, the Microchip logo, AnyRate, dsPIC, FlashFlex, flexPWR, Heldo, JukeBlox, KeeLoq, KeeLoq logo, Klear, LANCheck, LINK MD, MediaLB, MOST, MOST logo, MPLAB, OptoLyzer, PIC, PICSTART, PIC32 logo, RightTouch, SpyNIC, SST, SST Logo, SuperFlash and UNI/O are registered trademarks of Microchip Technology Incorporated in the U.S.A. and other countries.

ClockWorks, The Embedded Control Solutions Company, ETHERSYNCH, Hyper Speed Control, HyperLight Load, IntelliMOS, mTouch, Precision Edge, and QUIET-WIRE are registered trademarks of Microchip Technology Incorporated in the U.S.A.

Analog-for-the-Digital Age, Any Capacitor, AnyIn, AnyOut, BodyCom, chipKIT, chipKIT logo, CodeGuard, dsPICDEM, dsPICDEM.net, Dynamic Average Matching, DAM, ECAN, EtherGREEN, In-Circuit Serial Programming, ICSP, Inter-Chip Connectivity, JitterBlocker, KlearNet, KlearNet logo, MiWi, motorBench, MPASM, MPF, MPLAB Certified logo, MPLIB, MPLINK, MultiTRAK, NetDetach, Omniscient Code Generation, PICDEM, PICDEM.net, PICkit, PICtail, PureSilicon, RightTouch logo, REAL ICE, Ripple Blocker, Serial Quad I/O, SQL, SuperSwitcher, SuperSwitcher II, Total Endurance, TSHARC, USBCheck, VariSense, ViewSpan, WiperLock, Wireless DNA, and ZENA are trademarks of Microchip Technology Incorporated in the U.S.A. and other countries.

SQTP is a service mark of Microchip Technology Incorporated in the U.S.A.

Silicon Storage Technology is a registered trademark of Microchip Technology Inc. in other countries.

GestIC is a registered trademarks of Microchip Technology Germany II GmbH & Co. KG, a subsidiary of Microchip Technology Inc., in other countries.

All other trademarks mentioned herein are property of their respective companies.

© 2016, Microchip Technology Incorporated, Printed in the U.S.A., All Rights Reserved.

ISBN: 978-1-5224-0443-9



MICROCHIP

Worldwide Sales and Service

AMERICAS

Corporate Office

2355 West Chandler Blvd.
Chandler, AZ 85224-6199

Tel: 480-792-7200

Fax: 480-792-7277

Technical Support:

<http://www.microchip.com/support>

Web Address:

www.microchip.com

Atlanta

Duluth, GA

Tel: 678-957-9614

Fax: 678-957-1455

Austin, TX

Tel: 512-257-3370

Boston

Westborough, MA

Tel: 774-760-0087

Fax: 774-760-0088

Chicago

Itasca, IL

Tel: 630-285-0071

Fax: 630-285-0075

Cleveland

Independence, OH

Tel: 216-447-0464

Fax: 216-447-0643

Dallas

Addison, TX

Tel: 972-818-7423

Fax: 972-818-2924

Detroit

Novi, MI

Tel: 248-848-4000

Houston, TX

Tel: 281-894-5983

Indianapolis

Noblesville, IN

Tel: 317-773-8323

Fax: 317-773-5453

Los Angeles

Mission Viejo, CA

Tel: 949-462-9523

Fax: 949-462-9608

New York, NY

Tel: 631-435-6000

San Jose, CA

Tel: 408-735-9110

Canada - Toronto

Tel: 905-673-0699

Fax: 905-673-6509

ASIA/PACIFIC

Asia Pacific Office

Suites 3707-14, 37th Floor
Tower 6, The Gateway
Harbour City, Kowloon

Hong Kong

Tel: 852-2943-5100

Fax: 852-2401-3431

Australia - Sydney

Tel: 61-2-9868-6733

Fax: 61-2-9868-6755

China - Beijing

Tel: 86-10-8569-7000

Fax: 86-10-8528-2104

China - Chengdu

Tel: 86-28-8665-5511

Fax: 86-28-8665-7889

China - Chongqing

Tel: 86-23-8980-9588

Fax: 86-23-8980-9500

China - Dongguan

Tel: 86-769-8702-9880

China - Hangzhou

Tel: 86-571-8792-8115

Fax: 86-571-8792-8116

China - Hong Kong SAR

Tel: 852-2943-5100

Fax: 852-2401-3431

China - Nanjing

Tel: 86-25-8473-2460

Fax: 86-25-8473-2470

China - Qingdao

Tel: 86-532-8502-7355

Fax: 86-532-8502-7205

China - Shanghai

Tel: 86-21-5407-5533

Fax: 86-21-5407-5066

China - Shenyang

Tel: 86-24-2334-2829

Fax: 86-24-2334-2393

China - Shenzhen

Tel: 86-755-8864-2200

Fax: 86-755-8203-1760

China - Wuhan

Tel: 86-27-5980-5300

Fax: 86-27-5980-5118

China - Xian

Tel: 86-29-8833-7252

Fax: 86-29-8833-7256

ASIA/PACIFIC

China - Xiamen

Tel: 86-592-2388138

Fax: 86-592-2388130

China - Zhuhai

Tel: 86-756-3210040

Fax: 86-756-3210049

India - Bangalore

Tel: 91-80-3090-4444

Fax: 91-80-3090-4123

India - New Delhi

Tel: 91-11-4160-8631

Fax: 91-11-4160-8632

India - Pune

Tel: 91-20-3019-1500

Japan - Osaka

Tel: 81-6-6152-7160

Fax: 81-6-6152-9310

Japan - Tokyo

Tel: 81-3-6880-3770

Fax: 81-3-6880-3771

Korea - Daegu

Tel: 82-53-744-4301

Fax: 82-53-744-4302

Korea - Seoul

Tel: 82-2-554-7200

Fax: 82-2-558-5932 or

82-2-558-5934

Malaysia - Kuala Lumpur

Tel: 60-3-6201-9857

Fax: 60-3-6201-9859

Malaysia - Penang

Tel: 60-4-227-8870

Fax: 60-4-227-4068

Philippines - Manila

Tel: 63-2-634-9065

Fax: 63-2-634-9069

Singapore

Tel: 65-6334-8870

Fax: 65-6334-8850

Taiwan - Hsin Chu

Tel: 886-3-5778-366

Fax: 886-3-5770-955

Taiwan - Kaohsiung

Tel: 886-7-213-7828

Taiwan - Taipei

Tel: 886-2-2508-8600

Fax: 886-2-2508-0102

Thailand - Bangkok

Tel: 66-2-694-1351

Fax: 66-2-694-1350

EUROPE

Austria - Wels

Tel: 43-7242-2244-39

Fax: 43-7242-2244-393

Denmark - Copenhagen

Tel: 45-4450-2828

Fax: 45-4485-2829

France - Paris

Tel: 33-1-69-53-63-20

Fax: 33-1-69-30-90-79

Germany - Dusseldorf

Tel: 49-2129-3766400

Germany - Karlsruhe

Tel: 49-721-625370

Germany - Munich

Tel: 49-89-627-144-0

Fax: 49-89-627-144-44

Italy - Milan

Tel: 39-0331-742611

Fax: 39-0331-466781

Italy - Venice

Tel: 39-049-7625286

Netherlands - Drunen

Tel: 31-416-690399

Fax: 31-416-690340

Poland - Warsaw

Tel: 48-22-3325737

Spain - Madrid

Tel: 34-91-708-08-90

Fax: 34-91-708-08-91

Sweden - Stockholm

Tel: 46-8-5090-4654

UK - Wokingham

Tel: 44-118-921-5800

Fax: 44-118-921-5820

07/14/15